

IVECO TRAKKER

February 2013

AD / AT 380T38 WH

Rigid 6x6

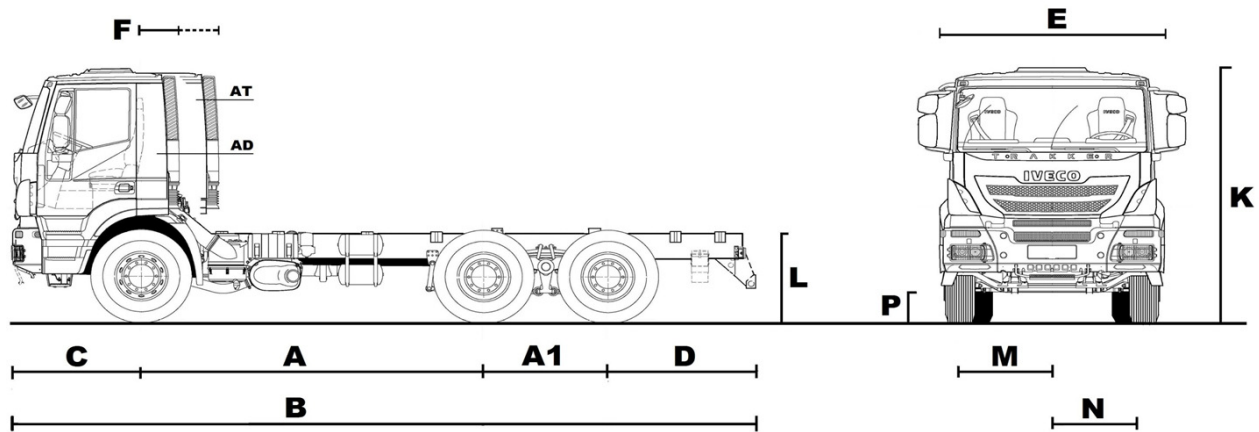

WEIGHTS (kg.)	G.V.W.	G.C.W.	Front axle	Rear axle
Design weights (std.)	34.000	44.000	8.000	26.000
Design weights (opt.)	38.000	55.000*	8.500	30.000

* Irregular towing operations (max gradient 7%)

KERBWEIGHTS (kg.) cab / wb.	short	3.500	3.820
Front axle		4.750	4.775
Rear axle		4.670	4.695
Total		9.420	9.470
PAYLOAD (kg.) @ G.V.W.		24.580	24.530

DIMENSIONS (mm)					
A	Wheelbase			3.500	3.820
A1	Tandem			1.390	1.390
B	Overall length (over bumpers)			7.997	8.267
C	Front overhang			1.440	1.440
D	Rear overhang			1.490	1.850
E	Cab width			2.550	2.550
G	Back of cab to end of frame	short		6.109	6.379
		long		5.669	5.939
F	Cab gap	short		445 (760)	445 (760)
	(with vertical exhaust muffler)	long		900 (1210)	900 (1210)
K	Cab height (unladen)			3.234	3.234
L	Frame height at rear frame end			1.159	1.159
	Frame thickness			10	10
	Turning circle (wall to wall)			19.100	19.900
M	Front track			1.981	1.981
N	Rear track			1.827	1.827
P	Ground clearance (front)			380	380
	Ground clearance (rear)			310	310

TYRES & WHEELS	Tyre code	Mission	Tyre dimensions		Wheel dimensions	
			Front	Rear	Front	Rear
Standard	20079	C	13R22,5	13R22,5	22.5x9.00	22.5x9.00
Option	20497	D	12.00R20	12.00R20	20x8.50	20x8.50
Option	20764	D	12.00R24	12.00R24	24x8.50	24x8.50

Tyre mission code: B = regional; C = all use; D = mix/off road

NOTE: Weights are to standard specification and include water, oils, tool box, jack and 75 kg. driver. Kerb weights are subject to a manufacturing tolerance of +/- 5%. Sleeper cab adds +110 kg. (95 on front, 15 kg. on rear). Medium Roof on Sleeper Cab adds +230 kg. and H=625 mm. Automated gearbox reduces -45 kg.

IVECO TRAKKER

AD / AT 380T38 WH

ENGINE	Iveco Cursor 13
Turbocharger	Waste-Gate valve
Cylinders in line	6
Bore (mm)	135
Stroke (mm)	150
Capacity (litres)	12,88
Max power (HP/kW)	380/279
@ rpm	1500-1900
Max torque (Nm/mKg)	1800/183
@ rpm	900-1400
E.E.C. emissions regulation	Euro 3
Cooling fan	2 speed electro-magnetic
Fuel system	Unit pump injector
Speed limiter	90kmh
Cruise control	Standard
Air admission / Filter type	Rear cab snorkel / dry - Horizontal

GEARBOXES	EUROTRONIC	MECHANICAL	
	16AS2630 TO	16S2220 TO	
Ratios			
1st	14,12		13,80
2nd	11,68		11,54
3rd	9,54		9,49
4th	7,89		7,93
5th	6,52		6,53
6th	5,39		5,46
7th	4,57		4,57
8th	3,78		3,82
9th	3,09		3,02
10th	2,56		2,53
11th	2,09		2,08
12th	1,73		1,74
13th	1,43		1,43
14th	1,18		1,20
15th	1,00		1,00
16th	0,83		0,84
Rev	13,07 10,8		12,92 10,8

PERFORMANCE	(with standard tyres)				
Type: ZF 16 AS 2630 TO					
Axle ratios available	5,01	4,23	4,67	5,56	6,09
Geared speed (km/h)	94	111	101	85	77
Gradeability % @ 34 t G.V.W.	68	54	61	79	93
Gradeability % @ 44 t G.C.W.	48	39	44	55	62
Type: ZF 16 S 2220 TO					
Axle ratios available	4,67	3,79	4,23	5,01	5,56
Geared speed (km/h)	100	123	110	93	84
Gradeability % @ 34 t G.V.W.	59	45	52	65	76
Gradeability % @ 44 t G.C.W.	43	34	38	47	53

CLUTCH	
Type	Single plate, diaphragm spring, pull type.
Diameter (mm)	(17") 430 mm

TRANSFER BOX	TC 2200, Gb independent, carter in aluminium,
Ratio	On road: 1/1 – Off Road: 1/1,6.
Inter axle split	Front 20% - Rear 80%

BRAKES	
Type	2 independent pneumatic circuits
Service	A.B.S. + E.B.L. on rear
Front axle	Duo-duplex drums. Dia.:410x180mm Friction area: 2884 cm2
Rear axle	Duo-duplex drums. Dia.:410x200mm Friction area: 3220 cm2
Parking	Mechanical with spring cylinder, rear.
Emergency	Combined with parking brake.
Air reservoirs	5 x 20 litres, steel
Engine – Iveco Turbo Brake	Decompression. Power: 295kW @ 2400 rpm
Air compressor	352cc – single cylinder
Heated air dryer	Air Processing Unit
Trailer connections	15 pin plug as alternative 7+7 pin

Cursor 13 - 380 HP

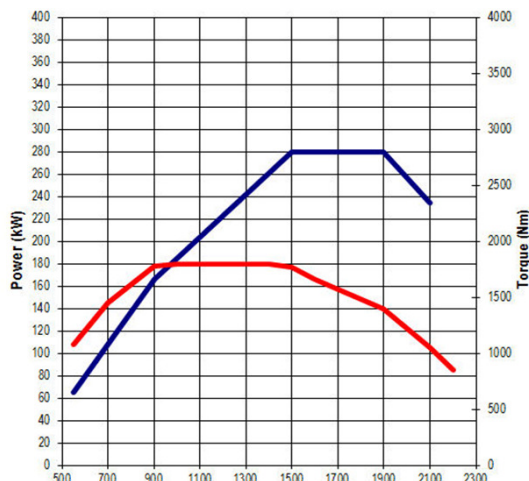

ELECTRICS

Tension	24v negative earth return
Alternator	28v, 90A
Starter	24v, 5.5kW
Batteries	2 x 12v, 170Ah
Circuits protected	By fuse
System	Multiplex - CAN line data bus

SUSPENSIONS

Front	Parabolic leaf
Rear	Semielliptic leaf
Anti roll bar	Front
Shock absorbers	2 on front

STEERING

Type ZF 8098	Power assisted
Steering wheel diameter	510 mm

AXLES

Steering and drive with single wheels	Iveco 5985/2D. Banjo.
Drive with twin wheels	Iveco 453291.Tandem. Hub reduction.
Differential lock	Cross and inter axle.
Rear axle ratio	See Performances.

FUEL TANK

Type and capacity	300lt., steel with lockable fuel cap.
-------------------	---------------------------------------

CAB INTERIOR

Active Time

Interior incorporating, air suspended 3-way adjustable driver's seat, inertia reel belt. Passenger seat 2 way adjustable with inertia reel belt. Soft feel dashboard with multi-functional steering wheel incorporating touch button menu controls for the real time digital dash display. Dual scale speedometer. All gauge functions monitored using international symbols. Heater. Left and right hand entry assist handles. Pneumatic adjustable steering column, 2 column mounted control stalks, left stalk operating the indicators, main beam, windscreen wash wipe, (if provided) right stalk operating Eurotronic 2 gear change, engine brake, cruise control and variable speed limiter. If provided, left of the steering column is the dash mounted Eurotronic gearbox controls for automatic and semi-automatic modes, neutral, reverse and low speed manoeuvring mode (forward and reverse). Overhead console for CB radio. Courtesy and map reading lights. Electronic PTO switch and in cab preparation. Fabric trim cab interior. Single low level bunk with under bunk storage, bottle holder & storage and control panel.

Active Day

As above without bunk & under storage, with rear bulk head storage & writing pad.

CAB EXTERIOR

Active Time

Forward control cab. Galvanised pressed steel construction, with SMC for vulnerable parts. Helical spring suspension and dampers. Hydraulic cab tilt to 60 deg. Tinted electric door windows and tinted laminated screen. Manual rear-view mirrors plus kerb and wideangle mirrors, according to 2003/97/EC. Blind rear cab panel. External stowage for tools. Steel front bumper.

Active Day

As above without external stowage.

CHASSIS

Type	Ladder construction. Pressed steel side members and riveted and bolted cross members.
Side member length (mm)	309
Flange width (mm)	80

NOTE: The information in this literature is intended to be of a general nature only. Iveco reserves the right to modify or change specification at any time.