

EURO CARGO

ML 180E28

Rigid 4x2

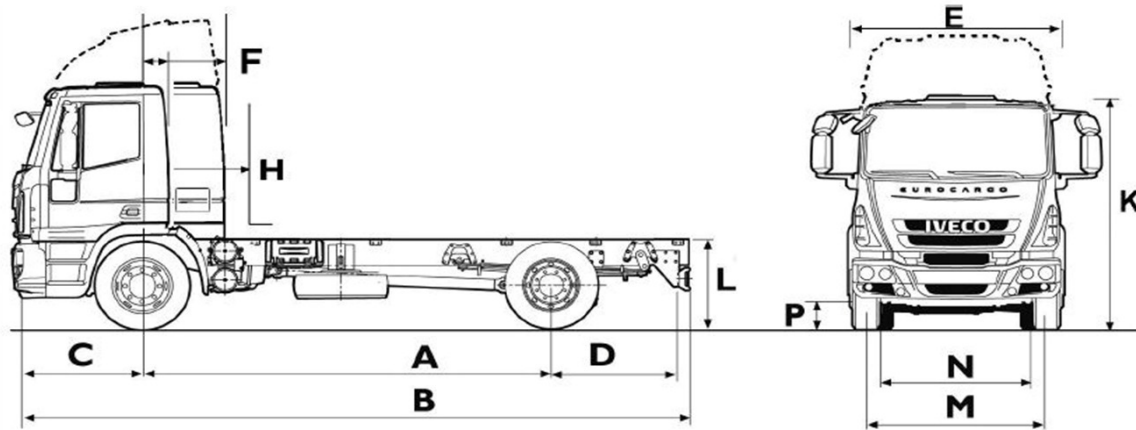

WEIGHTS (kg.)	G.V.W.	G.C.W.	Front axle	Rear axle
Design weights (std.)	18000	21500	7100	11500
Design weights (opt.)	18000	21500	7100	11500

KERBWEIGHTS (kg.) cab / wb.	short	3690*	4185	4590	4815	5175	6210*
Front axle		3405	3465	3475	3505	3530	3605
Rear axle		1850	1855	1855	1890	1915	2025
Total		5255	5320	5330	5395	5445	5630
PAYLOAD (kg.) @ G.V.W.		12745	12680	12670	12605	12555	12370

* Not available with long cab

DIMENSIONS (mm)			3690	4185	4590	4815	5175	6210
A	Wheelbase		3690	4185	4590	4815	5175	6210
B	Overall length (over bumpers)		6269	6944	7686	8114	8744	9891
C	Front overhang		1352	1352	1352	1352	1352	1352
D	Rear overhang		1133	1313	1650	1853	2123	2235
E	Cab width		2495	2495	2495	2495	2495	2495
F	End of cab	short	265	265	265	265	265	265
		long		845	845	845	845	
H	Cab gap	short	120	120	120	120	120	120
		long		965	965	965	965	
	Recommended body length	short	4400	5100	5700	6100	6600	7600
		long		4200	4800	5100	5600	
K	Cab height (unladen)		2835	2835	2835	2835	2835	2835
L	Frame height at rear frame end		1080	1081	1083	1084	1085	1085
	Frame thickness		6	6,7	7,7	7,7	7,7	7,7
	Turning circle (wall to wall)		14390	15900	17130	17810	18910	22110
M	Front track		1970	1970	1970	1970	1970	1970
N	Rear track		1815	1815	1815	1815	1815	1815
P	Ground clearance (front)		232	232	232	232	232	232
	Ground clearance (rear)		179	179	179	179	179	179

TYRES & WHEELS	Tyre code	Mission	Tyre dimensions	
			Front	Rear
Standard	20498	C	295/80 R 22,5	295/80 R 22,5
Option	20231	C	315/80 R 22,5	315/80 R 22,5
Option	20757	B	12 R 22,5	12 R 22,5

Tyre mission code: B = regional; C = all use; D = mix/off road

IVECO

ML 180E28

ENGINE

Turbocharger	IVECO TECTOR
Cylinders in line	Turbocharged and intercooled
Bore (mm)	6
Stroke (mm)	102
Capacity (litres)	120
Max power (HP/kW)	5,88
@ rpm	275/202
Max torque (Nm)	2700
@ rpm	930
E.E.C. emissions regulation	1200 - 2100
Governor	Euro 3
Cooling fan	All speeds
Fuel system	Viscostatic
Speed limiter	Common rail - Bosch
	90kmh

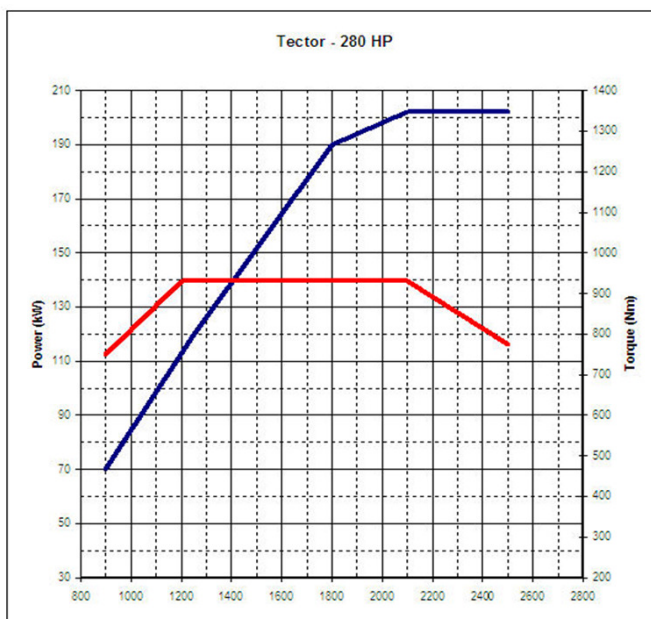

GEARBOXES

	MEC. 9 SPEED ZF 9S1110 TO		AUTOMATIC ALL. S 3000	
Ratios				
1st	9,48		3,49	
2nd	6,58		1,86	
3rd	4,68		1,41	
4th	3,48		1,00	
5th	2,62		0,75	
6th	1,89			
7th	1,35			
8th	1,00			
9th	0,75			
Rev	8,97		5,03	

PERFORMANCE

(with standard tyres)

Type: ZF 9S1110 TO

Axle ratios available	4,89	4,56	5,13	5,63
Geared speed (km/h)	141	151	134	122
Gradeability % @ 18 t G.V.W.	42	39	44	50

Type: ALL. S 3000

Axle ratios available	4,89	4,56	5,63	6,14	6,43
Geared speed (km/h)	141	151	122	112	107
Gradeability % @ 18 t G.V.W.					

CLUTCH

Type	Single plate, diaphragm spring, pull type.
Diameter (mm)	15" (380 mm)
	Asbestos free.

BRAKES

Type	2 independent pneumatic circuits
Service	A.B.S. + E.B.L.
Front axle	Discs. 432 mm diameter
Friction area front	1632 cm ²
Rear axle	Discs. 432 mm diameter
Friction area rear	1632 cm ²
Parking	Mechanical with spring cylinder, rear.
Emergency	Combined with parking brake.
Air reservoirs	2 x 20 litres, steel
Engine brake	Standard exhaust brake
Air compressor	225 cc - single cylinder
Air dryer	Air Processing Unit

ELECTRICS

Tension	24v negative earth return
Alternator	28v, 70A
Starter	24v, 4 kW
Batteries	2 x 12v, 110Ah
Circuits protected	By fuse
System	Multiplex - CAN line data bus

SUSPENSIONS

Front	Parabolic
Rear	Parabolic
Anti roll bar	Front & rear
Shock absorbers	2 on front, 2 on rear

STEERING

Type	Power assisted
------	----------------

AXLES

Front	Iveco 5871/5. Rigid.
Rear	MS 13-165. Single reduction.
Differential lock	Cross axle available as option.

FUEL TANK

Type and capacity	180lt. with lockable fuel cap.
-------------------	--------------------------------

CAB INTERIOR

Day cab

Forward control cab. Fabric three way adjustable driver seat, dual fixed passenger seat. Overhead lockers with doors, Windowless rear wall with document net. Glove box. Four speed fan, air flow 500 m³/hr, 10 Kw. All gauges monitored using international symbols. Electronic tachograph for two drivers,. Fully adjustable steering column. Column mounted control stalks. Overhead console for radio and CB. Courtesy and map reading lights.

Sleeper cab

As per day cab plus: a lower bunk, storage box under bunk, reading light and bed module for controlling cab lights, electric windows, roof hatch.

CAB EXTERIOR

Day and sleeper cab

Pressed steel construction with SMC for vulnerable parts. Suspension: helical springs and dampers. Hydraulic manual tilt to 60 degrees. Rear view mirrors according to CEE 88/321.

CHASSIS

Ladder construction. Pressed steel side members and riveted and bolted cross members.

Wheelbases (mm)	Height (mm) x width (mm)
3690	274,5 x 80
4185	275,9 x 80
4590 - 6210	277,9 x 80

NOTE: The information in this literature is intended to be of a general nature only. Iveco reserves the right to modify or change specification at any time.